

**EQUIPOS DE FUSIÓN
Y MEDICIÓN**



BY FIBER SYSTEM

PRODUCT MANUAL

OPTICAL FIBER FUSION SPLICER

OPTICAL FIBER FUSION SPLICER



NEW PRODUCT LAUNCH

CLASSIC MASTERPIECE

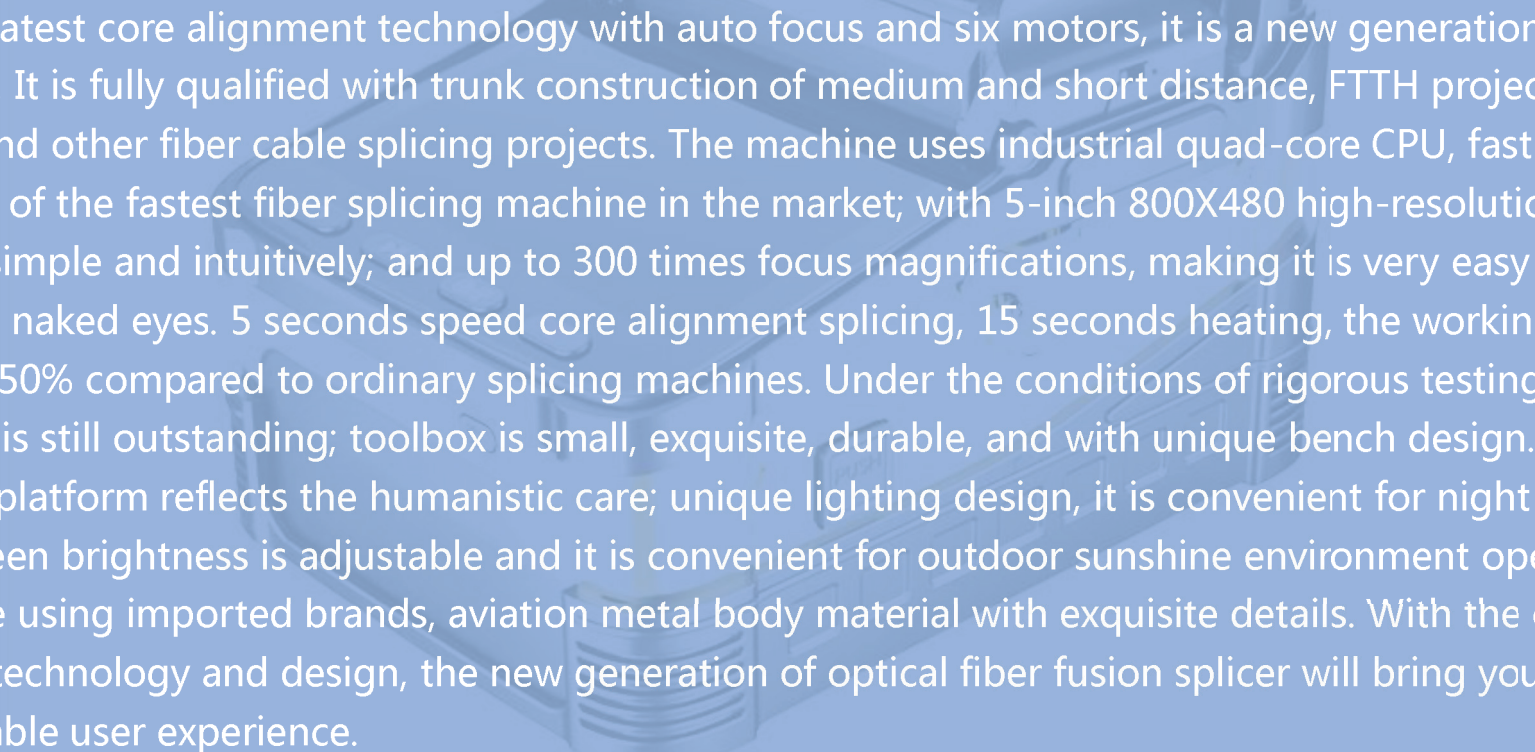

AI-9 use the latest core alignment technology with auto focus and six motors, it is a new generation of fiber fusion splicer. It is fully qualified with trunk construction of medium and short distance, FTTH project, security monitoring and other fiber cable splicing projects. The machine uses industrial quad-core CPU, fast response, is currently one of the fastest fiber splicing machine in the market; with 5-inch 800X480 high-resolution screen, the operation is simple and intuitively; and up to 300 times focus magnifications, making it is very easy to observe the fiber with naked eyes. 5 seconds speed core alignment splicing, 15 seconds heating, the working efficiency increased by 50% compared to ordinary splicing machines. Under the conditions of rigorous testing, the performance is still outstanding; toolbox is small, exquisite, durable, and with unique bench design. The design of operating platform reflects the humanistic care; unique lighting design, it is convenient for night construction or repair. Screen brightness is adjustable and it is convenient for outdoor sunshine environment operation. The core parts are using imported brands, aviation metal body material with exquisite details. With the combination of advanced technology and design, the new generation of optical fiber fusion splicer will bring you a reliable and comfortable user experience.

MASTERPIECE HIGH-END LUXURY

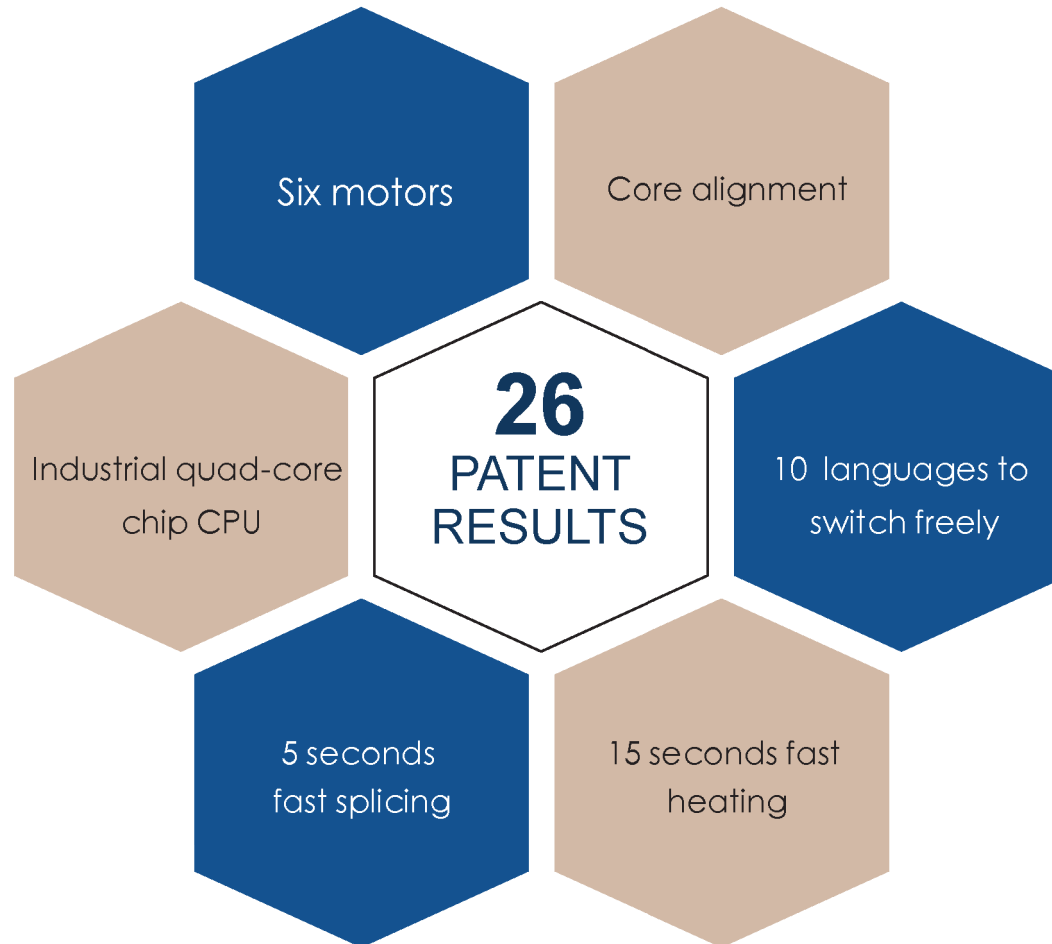

METAL BODY AESTHETIC DETAILS



Power Meter
VFL

VFL: Always on / flashing / off

Power Meter:

850nm/1300nm/1310nm/1490nm/1550nm/

1625nm Six states



BUILT-IN POWER METER AND VFL

Effectively measure connection loss, verify continuity, and help assess fiber link transmission quality.

METAL BODY

AESTHETIC DETAILS

PRODUCT DETAILS

Factory Address: No. 88 F. Qingsong Zone, Jiaxing Industrial Park, Qingsong District, Changshu, China. Factory Address: No. 88 F. Qingsong Zone, Jiaxing Industrial Park, Qingsong District, Changshu, China.

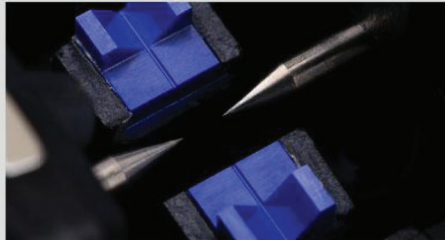

EXQUISITE DETAILS

Factory Address: No. 88 F. Qingsong Zone, Jiaxing Industrial Park, Qingsong District, Changshu, China. Factory Address: No. 88 F. Qingsong Zone, Jiaxing Industrial Park, Qingsong District, Changshu, China.



THE TOOLBOX

COMES WITH A STOOL TO FACILITATE THE CONSTRUCTION WORKERS.



Stool can bear 100KG

Remove the stool



Do not need to take out the splicer machine from the toolbox while working.

Fiber cleave operator station



Two layers

CORE PARTS QUALITY ASSURANCE

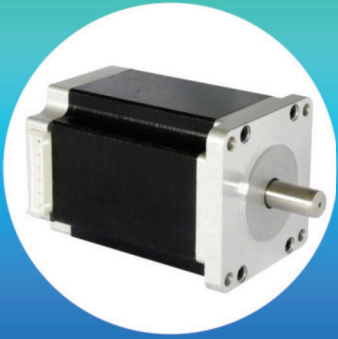

Siemens stepper motor



Roth ROUST linear guide



Sanyo lithium battery



Aviation metal material

Lighting for splicer



Convenient for night operation

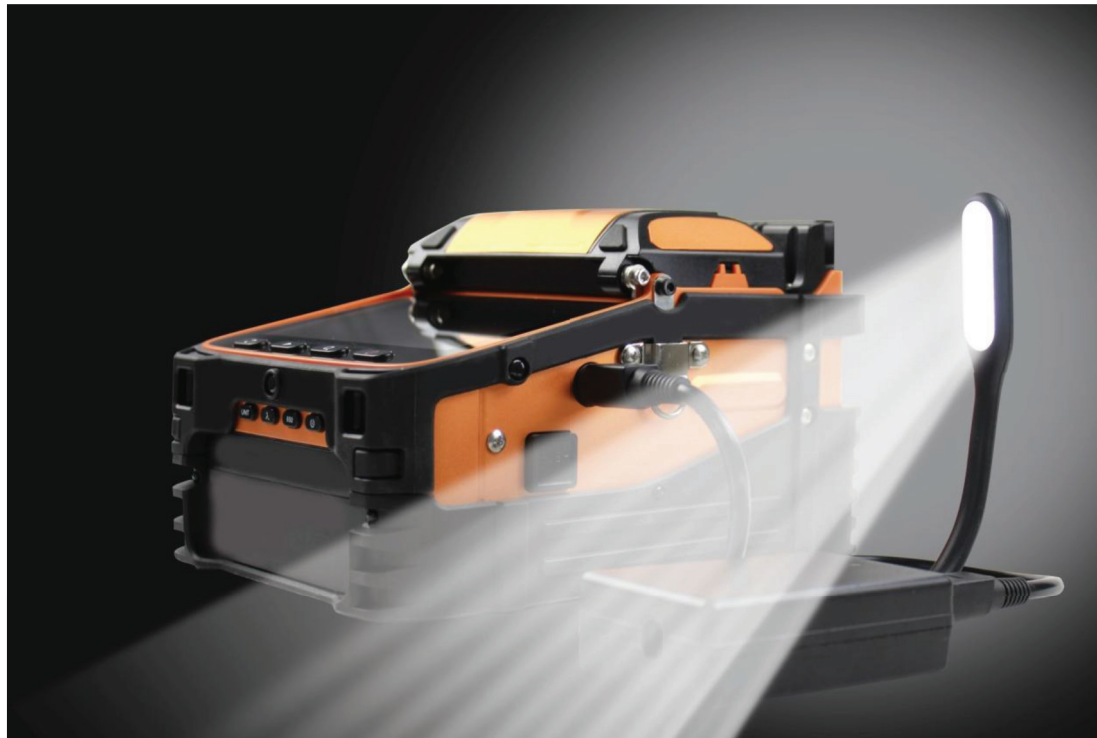

Can charge the phone



Avoid the use of outdoor construction mobile phones without electricity



INDUSTRIAL QUAD-CORE CHIP CPU

Synchronous operation / speed response / no jammed / super experience

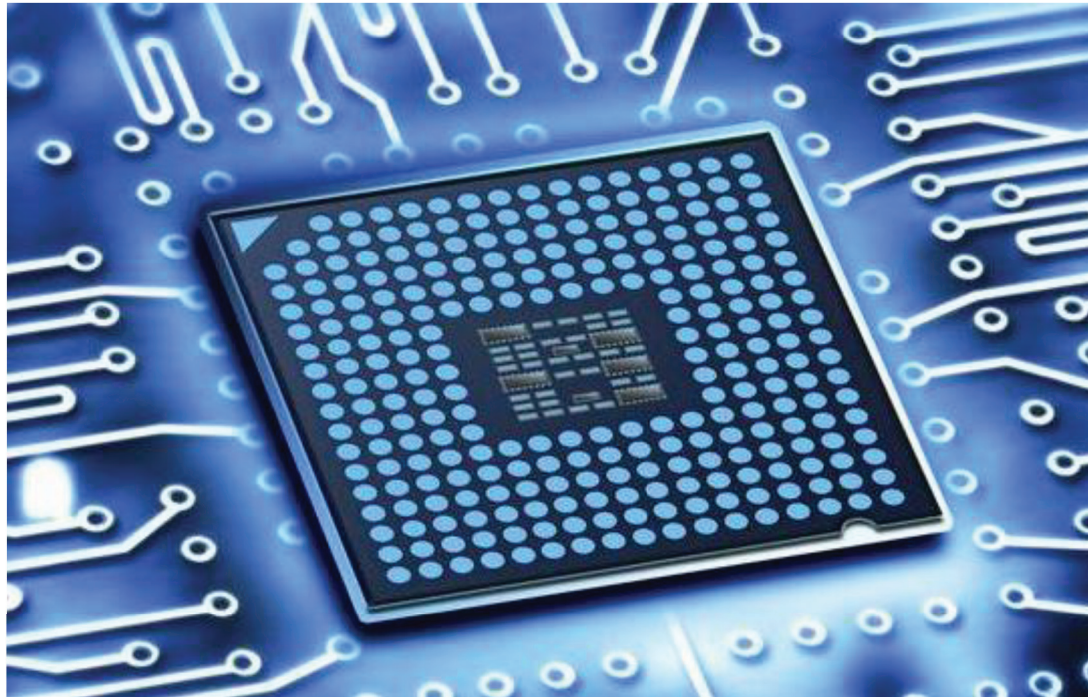

3 IN 1 FIBER HOLDER

SM, MM, bare fiber, pigtail, rubber-insulated, multi fiber cable

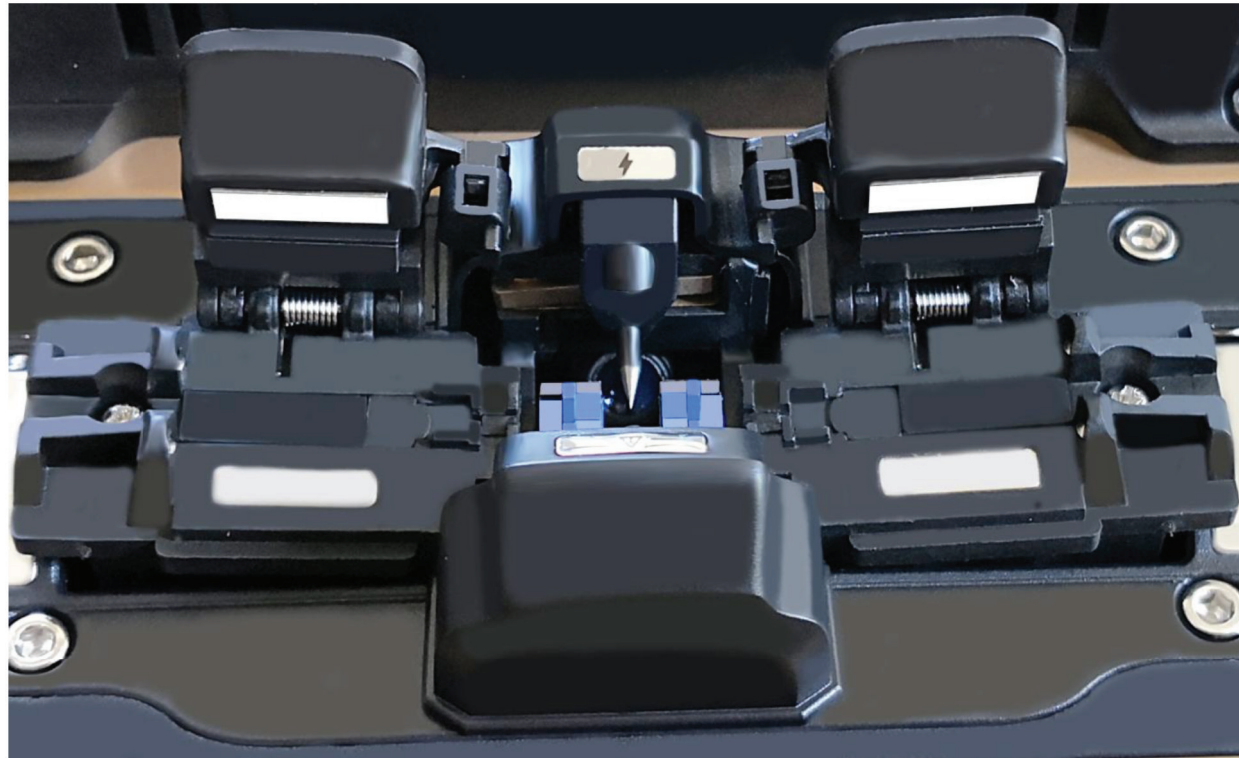

7800mAh LARGE CAPACITY BATTERY

charging time \leq 3.5 hours/continuous splicing and heating about 260 times



Press to popup
the battery

10 LANGUAGES TO SWITCH FREELY



Covers the global major user market



Show good performance in plateau, desert, and extreme cold environment



BASIC PARAMETER

Fiber alignment	Core/cladding alignment / Manual alignment	Language Setting	10 languages to switch freely
Splicing time	5S	Tension Test	Standard 2N
Heating time	15S	Fiber holders	3 in 1 fiber holder, SM, MM, bare fiber, pigtail, rubber-insulated, multi fiber cable
Heating mode	Automatic heating (Preheating)	Magnification	300 for X or Y view, 150 for X or Y view
Focus mode	Six motors Auto focus	Screen	5 inch TFT color display
Applicable Fibers	SM(G.652&G.657)、MM (G.651) 、DS(G.657)、NZDS (G.655)	Splicing Mode	Normal / high precision splicing
Splice Loss	0.025dB (SM) 、 0.01dB (MM) 0.04dB (DS/NZDS)	Splicing method	Fully automatic、 Step by step splicing
Control technology	Real-time control and calibration of fusion ARC	Splicing record storage	Synchronize to the phone, the server to cloud storage unlimited
Return loss	Better than 60DB	Built-in battery	7800 mA high-capacity lithium battery, charging time ≤ 3.5 hours, continuous splicing and heating about 260 times
Fiber diameter	Cladding Diameter : 80-150μm Coating Diameter : 100-1000μm	Power supply	Input AC100-240V 50 / 60HZ, output DC13.5V / 4.8A, the current power mode can be identified, real-time detection of battery power
Fiber Cleave Length	Coating less than 250μm : 8-16mm Coating less than 250-1000μm:16mm	Operating Conditions	Temperature -15 ~ +50 °C, humidity: <95% RH (no condensation) Working altitude: 0 ~ 5000m. Resist max. wind speed: ≤ 15m / s
Software update Length	Automatically update、 Update by a key	Shrinkable tube	60mm、 50mm、 40mm、 25mm
Boot time	1 second	Product protection	Waterproof, dust proof, shock-resistant

Size

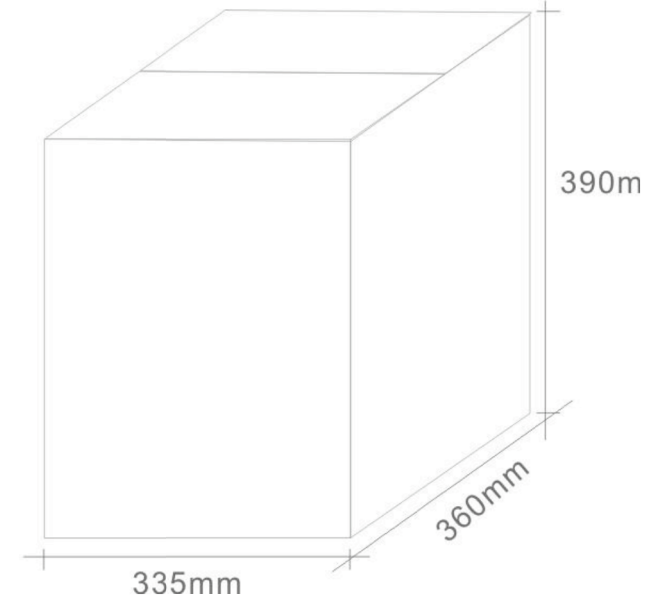
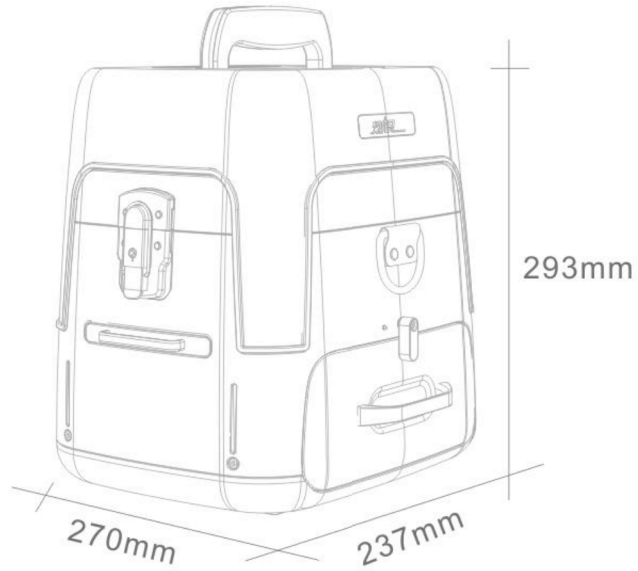
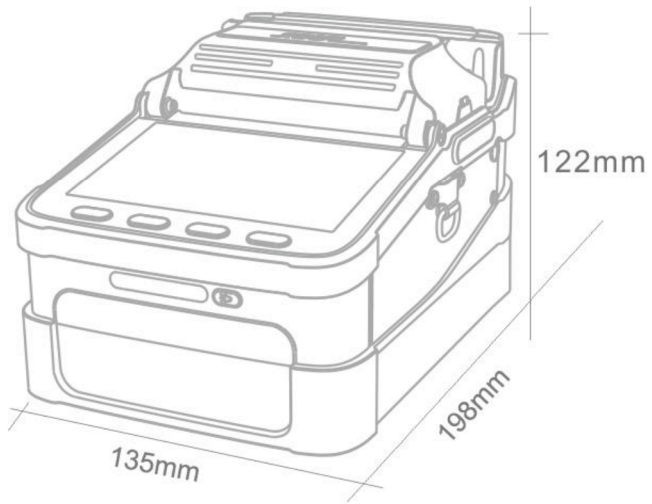

Machine weight

2.08kg (with battery)
1.60kg (without battery)

Toolbox weight

7.1kg (including machine and accessories)

Total weight

8.40kg

Accessories in the tool box



Fiber Cleaver

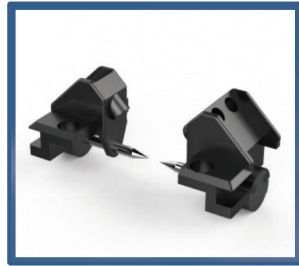

Spare electrode



Wire stripping pliers



Miller stripper



Hex key



carrying case

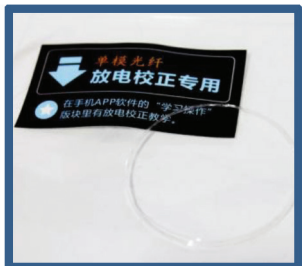

Fiber for
ARC calibration



Strap



Power Adapter



Alcohol Bottle



Brush



User's manual
Quality Certificate
Warranty Card

SERVICE COMMITMENT



Five years warranty, but these circumstances are not within the scope of this provision.

●01.Except for the cleaver, miller clamp, stripping pliers, fiber holders and other tools whose life depends on the frequency of use and the use of the environment. Also electrodes are consumption material which are not in the warranty.

●02.Battery and power adapter are warranty for one year, it is in free warranty where it is damaged or can not be charged in one year.



Matriz (China):
Sala 201, Bloque A, Edificio Digital
Garden City, 1079 Nanhai Avenue,
Distrito Nanshan, Shenzhen, China

 +8618927463845
+8613714906306

Sucursal Ecuador:
Urbanización 6 de Diciembre, Pasaje
San Blas OE6-49 y Princesa Toa,
Quito, Ecuador

 +593984510113
+593983373961

Sucursal Perú:
Calle Huaman Poma de Ayala 349 y
Av. Los Patriotas entre la quinta y
sexta frente al parque Virgen de
Guadalupe, San Miguel, Lima Perú.

 Fijo: +5115005857
Móvil: +51973644663

CONTACTOS

 @szfibersystemcoltd

 @szfibersystemcoltd

 <http://szfibersystem.com/>

 sale@szfibersystem.com